

M207 Series User Manual

TABLE OF CONTENTS

| | |
|---|----|
| TIRE PRESSURE MONITORING SYSTEMS, TPMS..... | 2 |
| NOTICE | 2 |
| SPECIFICATIONS | 3 |
| INCLUDED ACCESSORIES | 4 |
| SYSTEM INSTALLATION..... | 5 |
| DISPLAY UNIT INSTALLATION | 5 |
| SENSOR INSTALLATION..... | 6 |
| SENSOR INSTALLATION NOTICE | 7 |
| SYSTEM OPERATION | 8 |
| ADJUSTING OPERATING UNITS | 9 |
| ADJUSTING WARNING LEVELS | 9 |
| SYSTEM ALARM..... | 10 |
| SENSOR REPLACEMENT | 11 |
| APPENDIX..... | 11 |
| ANNEXES..... | 12 |
| WARRANTY POLICY | 13 |
| QUESTIONS..... | 13 |
| TROUBLESHOOTING GUIDE | 14 |



To ensure correct operation and service, read the following instructions before operating the Motorcycle TPMS accessory.

Tire Pressure Monitoring Systems, TPMS

Tire Pressure Monitoring Systems (TPMS) improves safety while driving. Once installed in your vehicle, the system will automatically monitor your tires in real-time for pressure and temperature. When any tire's pressure and/or temperature appear abnormal, the system will, in real-time, transmit signals to activate an alarm and show a digital figure to warn the driver of a problem. The system aids safety, can extend the tire life and help reduce fuel consumption.

NOTICE

FCC Notice

This device complies with Part 15 of the FCC Rules. Operation is subject to the following two conditions: (1) this device may not cause harmful interference, and (2) this device must accept any interference received, including interference that may cause undesired operation.

This equipment has been tested and found to comply with the limits for a Class B digital device, pursuant to Part 15 of the FCC Rules. These limits are designed to provide reasonable protection against harmful interference in a residential installation. This equipment generates uses and can radiate radio frequency energy and, if not installed and used in accordance with the instructions, may cause harmful interference to radio communications. However, there is no guarantee that interference will not occur in a particular installation.

If this equipment does cause harmful interference to radio or television reception, which can be determined by turning the equipment off and on, the user is encouraged to try to correct the interference by one or more of the factoring measures.

- Reorient or relocate the receiving antenna.
- Increase the separation between the equipment and receiver.
- Connect the equipment into an outlet on a circuit different from that to which the receiver is connected

Caution: Any changes or modifications in construction of this device which are not expressly approved by the party responsible for compliance could void the user's authority to operate the equipment.

To comply with the FCC RF exposure compliance requirements, this device and its antenna must not be co-located or operating to conjunction with any other antenna or transmitter.

System Scope of Use and Warnings

Tire Pressure Monitoring System, TPMS

This system is a sensing device designed to measure and display tire operation and / or activate an alert to the driver when pressure and temperature irregularities are detected. It is the responsibility of the driver to react promptly and with discretion to alerts. Abnormal tire inflation pressure should be corrected at the earliest opportunity.

Caution: The system is wireless RF product; therefore, it may not receive signal due to interference environment or incorrect operating or installation. When the system continually cannot receive signal from one of the tire sensor more than 10 minutes since the system be switched on, the system will show " E2 ". In this case, it may cause by a RF interference environment and driver needs to drive the vehicle to other place. If the display still cannot receive any correct signal from tire sensor, then, driver needs to find a nearby qualified tire maintain service for checking and maintain. It may cause by a tire sensor damaged or battery power consumption is low (the battery consumption will be lower than under normal using condition due to sensors need to send warning signal continually to driver) . If the system continually cannot receive signal from any sensors more than 10 minutes, the system might damaged and will show "E1". Driver needs to drive to other place (there might be a interference nearby) or send the system to agent for repair.

* System Installation and Usage

Proper use of the TPMS requires that a qualified tire service technician has properly installed the TPMS sensors. The system is intended for use on 2-wheel motorcycles. The pressure monitoring range is 74 Psi (Gauge), below instruction is Gauge value mentioned.

※ Suggestion: Please check valve stem every year to be sure the valve stem is not leaking air.

* Reacting to Alerts

When an alert or warning is received, reduce vehicle's speed and proceed to a safe location to stop where the tire can be inspected and /or serviced.

The low-pressure alert indicates that the air pressure has dropped to a selected minimum and a high-temperature alert indicates that the temperature of the tire content has surpassed the threshold value set.

*** Use of Chemicals**

Temporary resealing or re-inflation products containing internal sealants or propellants in any tire assembly may adversely affect the operation of the sensor/transmitter.

SPECIFICATIONS

| M207 Series RECEIVER SPECIFICATIONS | |
|--|--|
| Operating voltage | 9V-16V (DC) |
| Operating Current | < 150mA |
| Operating Temperature | -4°F to 176°F / -20°C to 80°C |
| Storage Temperature | -4°F to 176°F / -20°C to 80°C |
| Tire pressure/temperature reading unit | psi, bar, kPa / °F, °C |
| Dimension of display | L:4.5cm x W:6.2cm x H:2cm |
| SENSOR AND TRANSMITTER SPECIFICATIONS | |
| Operating Temperature | -22°F to 230°F / -30°C to 110°C |
| Storage Temperature | -40°F to 257°F / -40°C to 125°C |
| Operating humidity | Maximum 95% |
| Operating Frequency | 433.92 MHz± 50kHz |
| Pressure Monitoring Range | 0 ~ 74psi / 0 ~ 508kPa / 0 ~ 5.1bar |
| Pressure Reading Accuracy | ±1psi / ±10kPa / ±0.1bar (as normal pressure) |
| Temperature Monitoring Range | -22°F to 230°F / -30°C to 110°C |
| Temperature Reading Accuracy | ±4 °C in normal environmental conditions |
| Transmission Power | Maximum 75.1 dBuV/m |
| Battery | 3V |
| Direct Replacement for | <p>M207-115 : TR412 / 11.5mm for front & rear rim hole size</p> <p>M207-83 : TR430A / 8.3 mm for front & rear rim hole size</p> <p>M207-TM : TR430A / 8.3mm (front) & TR412 / 11.5mm (rear)</p> |

Note :

1. Due to different rims' spec, this product does not fit for all rims
2. Torque wrench is 40~45kgf-cm (4~4.5Nm ; 35.4~39.8 inlb).

INCLUDED ACCESSORIES

| | | |
|---|--------------------------|---|
| A | Display Unit | 1 |
| B | Sensors | 2 |
| C | Velcro for Display | 2 |
| D | Ties for power cord | 3 |
| E | Clip | 2 |
| F | L-shaped extension valve | 1 |
| | Manual | 1 |

M207-115

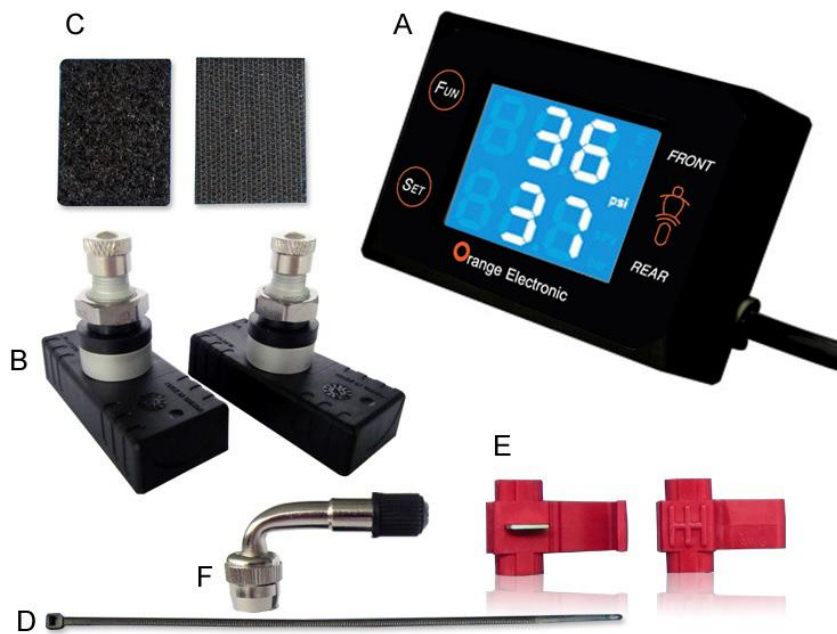

M207-83









SYSTEM INSTALLATION

The Orange Electronic Motorcycle TPMS Kit requires both the display unit and tire sensors to be installed. It is recommended to install the display unit before the two sensors.

DISPLAY UNIT INSTALLATION

| Step | Process |
|------|---|
| 1 | <p>Red Wire - positive (ACC) Black Wire - negative</p> <p>On the motorcycle's fuse box, connect red wire to positive electrical ACC connection and connect black wire to negative connection.</p> <p>Optional: Use clips (Accessory E) and ties (Accessory D) to help connect and fix electrical wires to the fuse box.</p> <p>Do not cut the wires more than 30cm due to the antenna(white wire) is inside the wires.</p> |
| 2 | <p>Attach velcro to the back of the display unit and place monitor at an appropriate position in front of driver.</p> |

SENSOR INSTALLATION

| Step | Process | Photo |
|------|--|---|
| 1 | *Only a professional tire dealer or mechanic should install the TPMS sensor |  |
| 2 | Remove each tire and release the air pressure. Take off the air valves from the wheel of the tire. (Note: Need to change the valve to a TPMS valve) |  |
| 3 | Match the number to each TPMS sensor with the correct wheel position on the motorcycle before installing. (IMPORTANT) F-1: Front tire R-2: Rear tire |  |
| 4 | Take off the valve cap and nut. Set up the new TPMS sensor valve in the wheel. After valve stem is through the rim, load nut. Use a wrench to secure the valve and tighten nut to 40~45kgf-cm (4~4.5Nm ; 35.4~39.8 inlb). |  |
| 5 | Inflate the tires to the manufacturer's recommended inflation level. Balance the tires to manufacturer's specifications: Balance tires using a balancing machine. A lead tire weight may need to be added for balancing. |  |

SENSOR INSTALLATION NOTICE

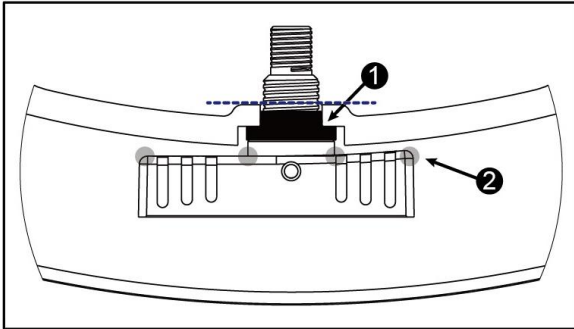

"Safe"

1. The grommet is invisible from the rim.
2. The sensor does not touch the rim.

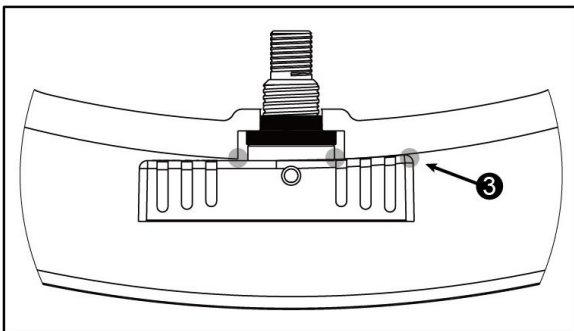

"Not Safe"

3. The sensor touches the rim.

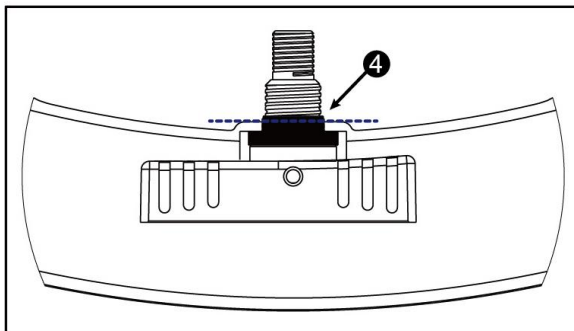

"Not Safe"

4. The grommet is visible from the rim.

SYSTEM OPERATION

Tire pressure and temperature will automatically be monitored when the TPMS unit is installed. Once accessory power is applied, the system will scan both tire sensors and display tire pressure and temperature in real time within 3 minutes.



(Fig.1)

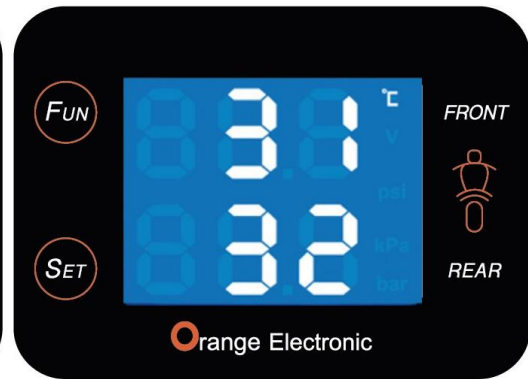

(Fig.2)

Use the 'Fun' (function) button to cycle between display modes:

Mode 1: Cycle between tire pressure and temperature.

Mode 2: Tire pressure. (Fig.1)

Mode 3: Tire temperature. (Fig.2)

Mode 4: Motorcycle battery voltage. (Fig.3)



(Fig.3)

Under any mode, if stay up to 30 seconds without operating, the display will record the mode automatically. Next time when restarting the display, it will be on the same mode.

When under mode 1/2/3, press "Fun" button for more than 3 seconds, the display will show sensor's battery voltage for few seconds, then display will go back to the previous mode.

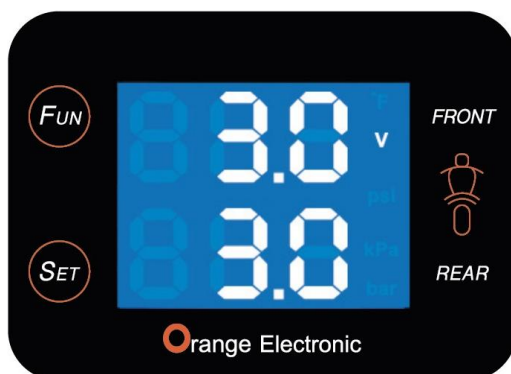

ADJUSTING OPERATING UNITS

ADJUSTING PRESSURE AND TEMPERATURE UNITS:

1. Press the "Set" button and release after 3 seconds when screen goes blank.
2. Press the "Set" button to choose psi, kPa or bar.
3. Once your preferred pressure unit is displayed, press and hold "Set" button for 3 seconds until the temperature unit is displayed
4. Press the "Set" button to choose Fahrenheit (F) or Celsius (C)
5. Once your preferred temperature unit is displayed, press and hold "Set" button for 3 seconds to set your preferred warning levels.

ADJUSTING WARNING LEVELS

Use the following steps to adjust the preset high/low pressure and high temperature warning levels for the individual front and rear tire.

The unit has been pre-loaded with alert thresholds, the details as below.

LOW/HIGH PRESSURE WARNING LEVELS:

Preset warning level:

Front High Warning Level: 45psi

Rear High Warning Level: 50psi

Low Warning Level: 27psi

Low Warning Level: 30psi

To modify the high and low pressure warning levels for the front and rear tires, use the following steps:

1. Press and hold the "Set" button for 1 second to enter warning level modification.
2. The display unit will enter warning level modification for the FRONT tire first.
3. The display will show "Lo" with flashing numbers.
4. Use the "Fun" button to change the front tire's low pressure warning level by +1psi within the ranges of 17-50psi. After reaching desired low warning level, select front low pressure by pressing the "Set" button.
5. The display will show "Hi" with flashing numbers.
6. Use the "Fun" button to change the front tire's high pressure warning level by +1psi within the ranges of 22-70psi. After reaching desired high warning level, select front high pressure warning by pressing the "Set" button.

※**Notice: After adjust the low pressure warning level, the lowest warning level of high pressure warning will +5 psi based on adjusted low pressure warning level.**

7. The display unit will enter warning level modification for the REAR fire second.
8. The display will show "Set" with flashing numbers.
9. Use the "Fun" button to change the rear tire's low pressure warning level by +1psi within the ranges of 17-50psi. After reaching desired low warning level, select rear low pressure by pressing the "Set" button.
10. The display will show "Hi" with flashing numbers.
11. Use the "Fun" button to change the rear tire's high pressure warning level by +1psi within the ranges of 22-70psi. After reaching desired high warning level, select rear high pressure warning by pressing the "Set" button.
12. After selecting the high and low warning levels for the front and rear fires, the display will automatically enter the set-up for high temperature warning level.

HIGH TEMPERATURE WARNING LEVEL:

Preset warning level: 80°C /176 °F

Preset warning range: 60~100°C =140~212 °F

1. The display unit will show "Hi" and flashing numbers.
2. Press the "Fun" button to modify flashing numbers to desired high temperature warning level.
3. Press the "Set" button once desired warning level has been reached to set warning level.
4. System will return to normal display mode, showing tire pressure and temperature.

SYSTEM ALARM



When the Motorcycle TPMS unit detects abnormal tire pressure, the display unit will keep showing tire pressure in red until the abnormal pressure has been corrected.



When the Motorcycle TPMS unit detects abnormal tire temperature, the display unit will keep showing tire temperature in red until the abnormal temperature has been corrected.



When the Motorcycle TPMS unit detects low battery voltage under 2.6V of the tire sensors, the display unit will keep showing sensor battery voltage in red until the sensor is replaced. The warning can be lifted by pressing "Set".

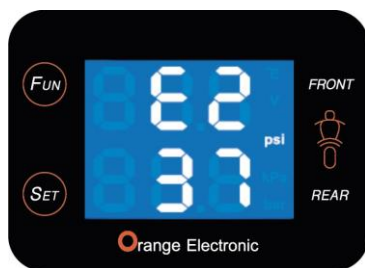

When the display cannot receive data from one of the sensors for about 10 minutes, the display will show "E2".

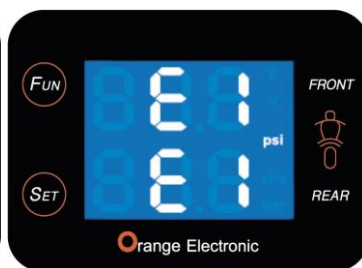

If the display cannot receive data from any of the sensors for more than 10 minutes, the display will show two "E1".



When the motorcycle battery voltage below 11V, in mode 3, the display will show in red number, but if switch to other mode, there will be a flickering low-voltage sign to remind the user.

※ It is driver's responsibility to act with caution and discretion in response to a warning from the display unit. Tire pressure and temperature issues should be corrected as safely and early as possible.

SENSOR REPLACEMENT

If a sensor's battery is low or if tires are rotated, the sensors need to be relearned by the display unit in order to display the correct information.

| Step | Process |
|------|--|
| 1 | Install a new Orange sensor according to directions (page 6). |
| 2 | Press the "Set" and "Fun" keys simultaneously for around 5 seconds. The screen will flash white and red text. Once a '1' is shown, release the buttons. This indicates that sensor replacement mode has been entered. |
| 3 | Press the 'Fun' key to switch between tire to be replaced. (1 = front, 2 = rear) |
| 4 | When select 1 (front tire), deflate the tire until the display shows 2, it means the display has recognized the front tire sensor. When display shows 2 (rear tire), deflate the tire until the display goes back to monitoring screen, it means the display has recognized the rear tire sensor. |
| 5 | Inflate tire back to manufacturer's recommended inflation level. |
| 6 | When the display unit recognizes the proper inflation level, it will return to normal display mode and monitor tire pressure and temperature in real-time. |

Appendix

Glossary

| | |
|--------------------------------|---|
| kPa | Pressure reading in Kilo Pascal |
| psi | Pressure reading in pound per square inch |
| Bar | Pressure reading in bar |
| °C | Temperature reading in degrees Celsius |
| °F | Temperature reading in degrees Fahrenheit |
| Inflating Pressure environment | Recommended inflation pressure of a tire at ambient temperature of 25°C / 77 °F by vehicle manufacturers. |
| Low Pressure Alert | Visual and audible warning will be activated when the tire's pressure is below the preset level. |

| | |
|-----------------------------|---|
| High Pressure Alert | Visual and audible warning will be activated when the tire's pressure is higher than the preset level. |
| High Temperature Alert | Visual and audible warning will be activated when the tire's temperature is higher than the preset level. |
| Display / Receiver Module | The electronic module mounted inside the vehicle that alerts the driver of any tire irregularities. |
| Sensor / Transmitter Module | The electronic module mounted on the wheels that measure the air pressure and temperature of the tire. |

Annexes

Annex 1

| kPa , psi, bar Conversion Table | | | | | | | | |
|---------------------------------|-----|-----|-----|-----|-----|-----|-----|-----|
| kPa | psi | bar | kPa | psi | bar | kPa | psi | Bar |
| 10 | 1 | 0.1 | 210 | 30 | 2.1 | 410 | 59 | 4.1 |
| 20 | 3 | 0.2 | 220 | 32 | 2.2 | 420 | 61 | 4.2 |
| 30 | 4 | 0.3 | 230 | 33 | 2.3 | 430 | 62 | 4.3 |
| 40 | 6 | 0.4 | 240 | 35 | 2.4 | 440 | 64 | 4.4 |
| 50 | 7 | 0.5 | 250 | 36 | 2.5 | 450 | 65 | 4.5 |
| 60 | 9 | 0.6 | 260 | 38 | 2.6 | 460 | 67 | 4.6 |
| 70 | 10 | 0.7 | 270 | 39 | 2.7 | 470 | 68 | 4.7 |
| 80 | 12 | 0.8 | 280 | 41 | 2.8 | 480 | 70 | 4.8 |
| 90 | 13 | 0.9 | 290 | 42 | 2.9 | 490 | 71 | 4.9 |
| 100 | 15 | 1 | 300 | 44 | 3.0 | 500 | 73 | 5 |
| 110 | 16 | 1.1 | 310 | 45 | 3.1 | 510 | 74 | 5.1 |
| 120 | 17 | 1.2 | 320 | 46 | 3.2 | 520 | 75 | 5.2 |
| 130 | 19 | 1.3 | 330 | 48 | 3.3 | 530 | 77 | 5.3 |
| 140 | 20 | 1.4 | 340 | 49 | 3.4 | 540 | 78 | 5.4 |
| 150 | 22 | 1.5 | 350 | 51 | 3.5 | 550 | 80 | 5.5 |
| 160 | 23 | 1.6 | 360 | 52 | 3.6 | 560 | 81 | 5.6 |
| 170 | 25 | 1.7 | 370 | 54 | 3.7 | 570 | 83 | 5.7 |
| 180 | 26 | 1.8 | 380 | 55 | 3.8 | 580 | 84 | 5.8 |
| 190 | 28 | 1.9 | 390 | 57 | 3.9 | 590 | 86 | 5.9 |
| 200 | 29 | 2 | 400 | 58 | 4.0 | 600 | 87 | 6 |

Annex 2

| °C To °F and °F To °C Conversion Table | | | | | |
|--|-----|----|-----|-----|-----|
| °C | °F | °C | °F | °C | °F |
| -40 | -40 | 20 | 68 | 80 | 176 |
| -30 | -22 | 30 | 86 | 90 | 194 |
| -20 | -4 | 40 | 104 | 100 | 212 |
| -10 | 14 | 50 | 122 | 110 | 230 |
| 0 | 32 | 60 | 140 | 120 | 248 |
| 10 | 50 | 70 | 158 | 125 | 257 |

WARRANTY POLICY

WARRANTY: Orange Electronic products are guaranteed from material defects for 365 days after the date of purchase. If the product fails under normal circumstances within the 1st year, Orange Electronic will repair or replace the product. Product will not be replaced or repaired if damaged from misuse or incorrect application. To obtain repair or replacement of the product under warranty, contact Orange Electronic or distributor. Proof of purchase and date of purchase are required to validate the warranty claim.

Orange Electronic is not liable for any director or consequential loss or property damage arising from the use of the product

QUESTIONS

Warning!!!

Only can replace new sensor by Orange TPMS replacement sensor (sensor can be purchased from agents). It cannot use other brands' TPMS sensors for replacement parts. Using other brands will cause failure reception and invalid warranty.

Any questions pertaining to warranty information or other questions not answered in the preceding pages can be answered by the place of purchase or by Orange Electronic service phone line or e-mail address:

+1(855)632-8767 (OEC-TPMS)
sales@orange-electronic.com

For updated TPMS information and Orange products visit the Orange Electronic website:

www.orange-electronic.com

Thank you for your purchase and enjoy your new Motorcycle TPMS

Troubleshooting Guide

A. The receiver shows no sign or any information after its power is turned on.

1. The power cord connector is not well connected with the receiver

Solution: Remove the power cord and plug it into the outlet again until it is connected completely.

2. The digits shown on the display panel become incomplete, or the light indicators become abnormal.

Solution : Send the defected receiver display back to agent for repair and reconfigure its ID follow "SENSOR REPLACEMENT" setting.

3. The fuse is blown in display

Solution : Send the defected receiver display back to agent for repair and reconfigure its ID follow "SENSOR REPLACEMENT" setting

B. The Set button or the Conversion button has no response.

1. The inner circuits of the receiver failed

Solution : Ask your distributor to have your receiver replaced, reconfigure its ID follow "SENSOR REPLACEMENT" setting, and send the defected receiver back to manufacturer for repair.

C. The receiver cannot receive signal from one tire after the power is turned on the numeric values representing the locations of those tires displayed on the screen become "E2".

1. There is interference from other electronic device in the vehicle.

Solution : Remove other electronic device in the vehicle to determine if TPMS is interfered by those removed devices.

2. The ID of the tire does not set up correctly

Solution : Reconfigure the ID of the tire follow "SENSOR REPLACEMENT" setting for single tire.

3. The transmitter of the tire failed.

Solution : Reconfigure the ID follow "SENSOR REPLACEMENT" setting for single tire and then send the defected transmitter back to manufacturer for repair.

D. The receiver cannot receive signal from any tire after the power is turned on the numeric values representing the locations of those tires displayed on the screen become “E1”.

| |
|--|
| 1. There is interference from other electronic device in the vehicle. |
| Solution : Remove other electronic device in the vehicle to determine if TPMS is interfered by those removed devices. |
| 2. The ID of the tire does not set up correctly |
| Solution : Reconfigure the ID of the tire follow “SENSOR REPLACEMENT” setting for single tire. |
| 3. The inner circuits of the display panel failed. |
| Solution : Ask your distributor to have your receiver replaced, reconfigure sensor ID follow “SENSOR REPLACEMENT” setting, and send the defected receiver back to manufacturer for repair. |

E. The pressure (or temperature) values show the wrong tire locations

| |
|--|
| 1. The IDs of the two tires are not configures correctly |
| Solution : Reconfigure the IDs of the tires follow “SENSOR REPLACEMENT” setting. |
| 2. After rotating the tires, it cannot reconfigure the IDs from sensors. |
| Solution : Reconfigure the IDs of the tires follow “SENSOR REPLACEMENT” setting. |